

Marcinkiewicz Co.



**Put Your Money
Where Your Mouth Is™ J.M.**

**Mouthpiece Product Guide
For
All Brasswind Instruments**

593 S.E 1st Avenue • Canby, Oregon 97013

Ph. 503-263-2456

Fax 503-263-2484

email:mmpco@teleport.com

The Marcinkiewicz Company Philosophy

Our goal is to offer players the best quality mouthpiece at each and every stage of their growth: first as a student and throughout their career as a professional musician.

Because the facial structure of young students change as they mature, our line of mouthpieces is carefully graduated, allowing students to progress more quickly (and enthusiastically!) as they find the correct "fit" for their changing anatomy. Now players have the means to progress in **logical, gradual increments** to find the correct mouthpiece for their unique needs.



Display Screen of our CNC lathe

In order to offer the highest quality product available for both students and professionals, we have integrated the most sophisticated **computer technology** with "old-world" craftsmanship. **There is no difference in quality between our student and professional mouthpieces.** Our state of the art computerized cutting lathes assure that the quality of design as well as the precise reproduction of every Marcinkiewicz mouthpiece is exact. This is truly a first. We measure our mouthpieces precisely to the thousandths of an inch. We do not use approximations or fractions, but precise figures.

"Our commitment is to quality and consistency- guaranteed* every time." J.M.

At the Marcinkiewicz Company, our philosophy is:

- 1) Quality** We produce the best quality mouthpiece in the world today. There is a and difference between saying you are the best and being the best. Our Precision customers demand it, so we give it. Our reputation of quality and precision speaks for itself. We put our money where your mouth is.
- 2) Efficiency** Our innovative cup and venturi designs have been proven to be more responsive, allowing the player to use less effort, enhancing intonation, sound and performance.
- 3) Choice** Choose a mouthpiece that fits comfortably and gives you the best results. Marcinkiewicz gives you a choice in logical order and sizes, and our large selection allows you to select the proper fit. A mouthpiece does not have to hurt to be viable, so the choice is yours.

We invest in maintaining the highest quality of manufacturing. The mouthpiece technician's job is to give the player the best possible mouthpiece. All of the mouthpiece manufacturers have something to offer and that benefits you. The choice belongs to the players. We are here to help you. Just remember to play what is best for you.

"Put your money where your mouth is!"™ - Joseph W. Marcinkiewicz

593 S.E 1st Avenue • Canby, Oregon 97013

Ph. 503-263-2456

Fax 503-263-2484

email:mmpco@teleport.com

About this Catalog

You may notice that the format of this catalog is different from other mouthpiece catalogs. In lieu of offering a description of each individual mouthpiece, we offer detailed specifications and a definition of each part of the mouthpiece so you, the student, educator, and player, can determine for yourself what mouthpiece is appropriate for your fit and application. Because of the nature of this format, this catalog can be used as a general reference for all brasswind mouthpieces, regardless of manufacturer.

Our standard mouthpieces come with our modified [C/V-cup](#). Our Designer/Signature models vary where the requirements of the artist took precedence.

And for the players that have grown accustomed to conventional mouthpieces, we also offer several mouthpieces that have the same interior dimensions that are of “classic” designs. (These are shaded gray in the comparison column in the specification charts.) Marcinkiewicz offers these "classic" mouthpieces using our state of the art manufacturing techniques with the same quality that goes into every Marcinkiewicz product.

Custom Mouthpieces



Mr. Marcinkiewicz making a custom mouthpiece.

For players that have special needs, Marcinkiewicz Co. offers [custom brasswind mouthpieces](#). Mr. Marcinkiewicz is available for consultation to help clients determine exactly what they desire in a mouthpiece. Designing a mouthpiece involves both Mr. Marcinkiewicz and the client. We take great care to ensure that the customers get what they want. The ultimate designer of a custom mouthpiece is the player that commissions it. Although custom mouthpieces are the ultimate choice, we recommend trying stock equipment first. Remember, the choice is yours. We can create custom mouthpieces for any brasswind instrument, anything from cornetto to mellophone, hunting horn to peck horn.

A handwritten signature in cursive script that reads "Joseph Marcinkiewicz".

© Copyright 1998, Marcinkiewicz Co. All rights reserved.
No part of this document may be published without written permission.
Catalog Design by Marcinkiewicz Co.

Anatomy of a Mouthpiece

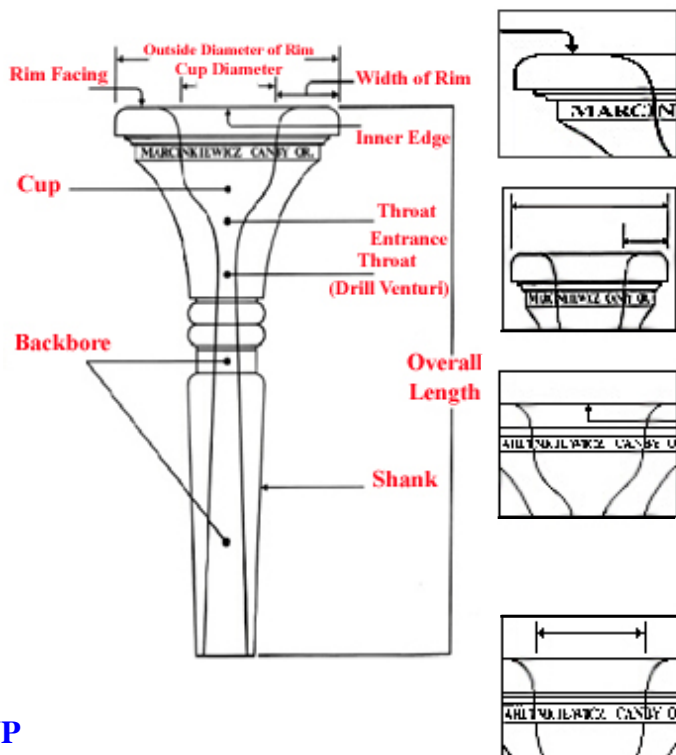

RIM FACING or CONTOUR

This feature is determined strictly by the lip size and teeth of the individual.

OUTSIDE DIAMETER and RIM WIDTH

These two features are determined simply by what feels comfortable to the player. A mouthpiece should not have to hurt to be playable.

INNER EDGE

The detail of this feature is most critical as it should not be so sharp that it cuts the flesh, yet not so rounded that there is no bite. Bite is defined as the ability to hold the mouthpiece to the lips without excess pressure, and still feel comfortable.

INSIDE CUP DIAMETER

Again, this is a critical part of the mouthpiece because it interfaces with the inner edge to insure proper fit and control. The size is again determined by the lips and teeth of the player.

CUP



The cup reflects the player's choice for quality of sound by both depth and shape. There are three basic types of cups: C-cup, V-cup and the Marcinkiewicz modified C/V-cup. A C-cup offers the player a darker sound. A V-cup offers efficiency. Our modified C/V-cup can offer the darker sound of a C-cup with the efficiency of a V-cup. The air stream is channeled through the center of our uniquely designed cup and venturi, through the backbore and directly into the horn to produce the desired sound. In short, the modified C/V-cup is easier to play. There is a difference between a C-cup and a V-cup and not every player can play both. The C/V-cup offers more choice to a wider range of players.

A deeper cup offers a darker sound and a shallower cup offers a brighter sound. Our modified C/V-cup mouthpieces can be shallower and still give the player more flexibility and versatility versus the C-cup or V-cup alone. Again, this situation is because the modified C/V-cup is more efficient.

Cup depth alone does not always dictate the sound quality. The overall shape of the cup factors in greatly. You may find mouthpieces in this catalog that have similar dimensions (inside cup diameter, outside cup diameter and depth) but play completely differently. Generally, this is due to a variation in cup shape. It is possible for a mouthpiece that has a shallower cup than another mouthpiece (again, with same rim dimensions) to have greater overall cup volume than the deeper mouthpiece, due to the contours of the cup. (See example figure A)

For example, our No.308/11/2C is shallower than a normal C-cup 11/2C. This allows us to give the sound of a 11/2C while increasing the efficiency. Efficiency is the ability of the mouthpiece to offer quicker response. Remember, when discussing terms of deeper or shallower that differences may be subtle. In this example, the difference is only a few thousandths of an inch. (No. 308/11/2C has a cup depth of .471 in. vs. .474 in. Cup depth of our E1.)

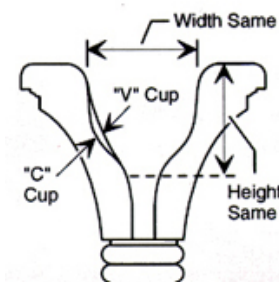
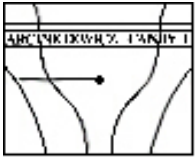

figure A



MEASUREMENT - INSIDE CUP DIMENSIONS

The inside cup dimension measurement is a critical piece of information any mouthpiece and the consistency and accuracy of the measurement is vital for the player. An accurate and consistent measurement allows a player to know exactly at what dimension is employed and a baseline for adjustments. We measure our trumpet, cornet, flugelhorn and French horn mouthpieces at .032 in. from the top of the rim to a consistent point. Tenor trombone, bass trombone and euphonium mouthpieces are measured .047 in. from the top, tuba and sousaphone mouthpieces .064 in. from the top. Fractions or approximations do not work the same way. (See example figure B)

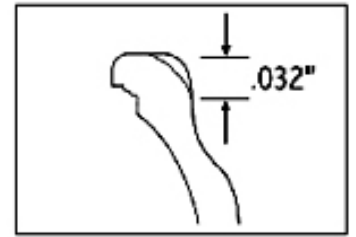
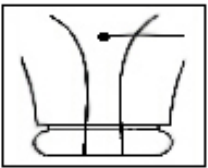

figure B

For example, our No.308/11/2C trumpet mouthpiece and the No.E1 both compare to a 11/2C, but have different inside bites*. This is very hard to detect by the naked eye. The precision of our measurements allows the difference to be evident. We took the guess work out.

The most frustrating issue for a player is to find a replacement of a favored mouthpiece due to loss or damage. Often the new mouthpiece is not like the original at all. Accurate and consistent measurement is a baseline, so you know what you are getting. "Without this baseline the process becomes a search that may have no end due to inconsistent information." J.M.

*See spec sheet



THROAT ENTRANCE

This is another critical area of the mouthpiece. The entrance determines how smoothly the air moves from the cup through the venturi or drill. If the entrance is too sharp it creates more resistance. If the entrance is more open it creates less resistance. By applying the correct taper the efficiency of the mouthpiece is improved further. Hence, the modified C/V-cup.

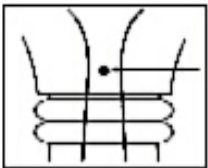

VENTURI (also known as Throat or Drill)

Generally, the size of the opening determines the amount of air the player can put through the instrument. Standard for a trumpet is a 27 or .144 in., trombone is an A or .234 in., and tuba is N or .302 in. There are a wide variety of throat sizes aside from these standards. See the Venturi Drill chart for other sizes in each category.

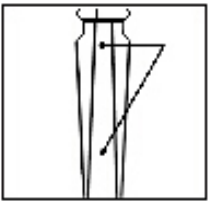

BACKBORE

Perhaps the second most critical area of a mouthpiece, the backbore either spreads the sound or channels it depending on how tight or open the design. The backbore influences the color, nuance and timbre of the mouthpiece. If you put a large backbore with a large cup mouthpiece the result will be a very warm, compassionate mouthpiece with feeling and depth of sound. The same mouthpiece with a tighter backbore will focus the sound that is being created, equalizing the lower end and accenting the upper end of upper harmonics. Our backbore designs enhance the player's ability to move easily throughout all registers of the instrument with uniformity of timbre and feel. Please note that the

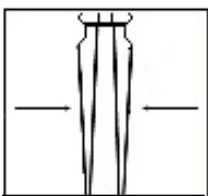

SHANK

We use a standard Morse taper. We make the Morse taper exact at .050" per inch -No more and no less! Please note, if your mouthpiece goes all the way in and touches the lead pipe it creates less resistance. There is a danger that the lead pipe will flair creating a burr resulting in resistance in the wrong place.

If the mouthpiece does not go in far enough and is more than a quarter inch away from the lead pipe, too much resistance is produced. This causes an undesirable sound for certain notes.

593 S.E 1st Avenue • Canby, Oregon 97013

Ph. 503-263-2456

Fax 503-263-2484

email:mmpco@teleport.com

Standard Trumpet Mouthpieces



Choice in Logical Sizes

Our standard trumpet mouthpieces are arranged in a logical ascending order from deep to shallow and wide to narrow (No.0 to No.15). This arrangement permits players to select mouthpieces by precise increments of depth to find the correct cup volume required by their situation. For example, if a No.7 trumpet mouthpiece is too deep and a No.10 too shallow, a No.8 or No.9 may be the best logical choice. (This is not true for other manufacturers. With Marcinkiewicz you do have a choice in logical sizes.) Note that No.6 - No.10 are similar to a Bach 101/2C.

Choice in Feel

The comparison column on this chart (and all charts in the catalog) offers rough comparisons to standard sizes. We are not offering copies of other brands in this series, but similar items using our own designs. The comparisons are given for casual references only.

Choice in Sound

For identification purposes, some of our numbers have a slash (/) and a reference after it. These are references to standard sizes. We provide them to make it easier for the customer to make a selection. For example, a No.4/7C is our number 4 and is most similar to a standard 7C. Other configurations of rim size and cup depth can also offer similar compression.

Please note that all standard trumpet mouthpieces, except for custom or the Designer/Signature models, are available in cornet. In addition, models No.0 - No.15 are available with an "S" (symphonic) backbone. This backbone broadens the sound offering a richer, darker tone.

"At Wigan Youth Jazz Orchestra we pride ourselves with offering our pupils the best possible education. Wherever possible this includes providing the best instruments and equipment available. In 1986 Bobby Shew introduced me to Marcinkiewicz Mouthpieces. The help and advice that I subsequently received from Joe Marcinkiewicz on mouthpiece design and selection has had a profound and direct effect on the sound of Wigan Youth Jazz Orchestra. For the individual players, the search for the RIGHT mouthpiece is over. They can now spend their time and effort on MAKING MUSIC!!"

"We are proud to say that the brass section of the Wigan Youth Jazz Orchestra choose to play on Marcinkiewicz Mouthpieces and as a result we can feel and hear the difference."

- Ian Darrington - Musical Director, Wigan Youth Jazz Orchestra, Lancashire, Great Britain

593 S.E 1st Avenue • Canby, Oregon 97013

Ph. 503-263-2456

Fax 503-263-2484

email:mmpco@teleport.com

Standard Trumpet Mouthpieces



Piccolo(*) Model No.	Outside Cup dia.	Inside Cup dia.	Cup Depth	Drill Venturi	Length	Rim	Comparison only
7PB	1.062 in. 26.97 mm	0.659 in. 16.74 mm	0.424 in. 10.77 mm	0.140 in. 3.56 mm	3.450 in. 87.63 mm	Medium Round	Bach 7E /10 1/2E
7PD/7E	1.062 in. 26.97 mm	0.659 in. 16.74 mm	0.424 in. 10.77 mm	0.144 in. 3.66 mm	3.450 in. 87.63 mm	Medium Round	Bach 7E /10 1/2E

** Piccolo Trumpet mouthpieces are also available with Cornet shank*

Trumpet Model No.	Outside Cup dia.	Inside Cup dia.	Cup Depth	Drill Venturi	Length	Rim	Comparison only
0	1.081 in. 27.46 mm	0.698 in. 17.73 mm	0.515 in. 13.08mm	0.144 in. 3.66 mm	3.450 in. 87.63 mm	Medium Round	Bach 5B expanded rim
1/5B	1.070 in. 27.18 mm	0.683 in. 17.35 mm	0.515 in. 13.08 mm	0.144 in. 3.66 mm	3.450 in. 87.63 mm	Medium Round	Bach 5B
2/7B	1.070 in. 27.18 mm	0.680 in. 17.27 mm	0.496 in. 12.60 mm	0.144 in. 3.66 mm	3.450 in. 87.63 mm	Medium Round	Bach 7B
3/5C	1.070 in. 27.18 mm	0.677 in. 17.20 mm	0.489 in. 12.42 mm	0.144 in. 3.66 mm	3.450 in. 87.63 mm	Medium Round	Bach 5C
4/7C	1.070 in. 27.18 mm	0.677 in. 17.20 mm	0.477 in. 12.12 mm	0.144 in. 3.66 mm	3.450 in. 87.63 mm	Medium Round	Bach 7C
5	1.070 in. 27.18 mm	0.663 in. 16.84 mm	0.475 in. 12.07 mm	0.144 in. 3.66 mm	3.450 in. 87.63 mm	Medium Round	Bach 5C
6/10 1/2 C	1.062 in. 26.97 mm	0.663 in. 16.84 mm	0.464 in. 11.97 mm	0.144 in. 3.66 mm	3.450 in. 87.63 mm	Medium Round	Smaller than Bach 10 1/2 C
7	1.062 in. 26.97 mm	0.663 in. 16.84 mm	0.453 in. 11.51 mm	0.144 in. 3.66 mm	3.450 in. 87.63 mm	Medium Round	Smaller than Bach 10 1/2 C
8	1.062 in. 26.97 mm	0.663 in. 16.84 mm	0.450 in. 11.43 mm	0.144 in. 3.66 mm	3.450 in. 87.63 mm	Medium Round	Smaller than Bach 10 1/2 C
9	1.062 in. 26.97 mm	0.663 in. 16.84 mm	0.441 in. 11.20 mm	0.144 in. 3.66 mm	3.450 in. 87.63 mm	Medium Round	Smaller than Bach 10 1/2 C
10	1.062 in. 26.97 mm	0.663 in. 16.84 mm	0.440 in. 11.18 mm	0.144 in. 3.66 mm	3.450 in. 87.63 mm	Medium Round	Smaller than Bach 10 1/2 C
11	1.062 in. 26.97 mm	0.642 in. 16.31 mm	0.439 in. 11.15 mm	0.144 in. 3.66 mm	3.450 in. 87.63 mm	Medium Round	Bach 7E or 13A4A
12	1.062 in. 26.97 mm	0.642 in. 16.31 mm	0.437 in. 11.10 mm	0.144 in. 3.66 mm	3.450 in. 87.63 mm	Medium Round	Bach 7E or 13A4A
13	1.062 in. 26.97 mm	0.642 in. 16.31 mm	0.435 in. 11.05 mm	0.144 in. 3.66 mm	3.450 in. 87.63 mm	Medium Round	Bach 7E or 13A4A
14	1.062 in. 26.97 mm	0.642 in. 16.31 mm	0.433 in. 11.00 mm	0.144 in. 3.66 mm	3.450 in. 87.63 mm	Medium Round	Bach 7E or 13A4A
15	1.062 in. 26.97 mm	0.642 in. 16.31 mm	0.430 in. 10.92 mm	0.144 in. 3.66 mm	3.450 in. 87.63 mm	Medium Round	Bach 7E or 13A4A

593 S.E 1st Avenue • Canby, Oregon 97013

Ph. 503-263-2456

Fax 503-263-2484

email:mmpco@teleport.com

Designer/Signature/ “Classic”/Trumpet Mouthpieces



“The best thing
I've put to my
chops”

Scott Englebright,
*Lead Trumpet
Maynard Ferguson &
Big Bop Nouveau
Plays Marcinkiewicz E14*

These mouthpieces are made to each specific player's specifications. Measurements such as inner diameter venturi, etc., are not arranged systematically, however this line is also numbered progressively by cup depth from deep to shallow.

Each of our endorsees chose a Marcinkiewicz Designer/Signature Mouthpiece because of their belief in the product. Each of these mouthpieces were designed for a specific player at a specific point in time. Many play our mouthpiece exclusively.

Designer/Signature models are available in flugelhorn and cornet as a special order only. Custom mouthpieces are also available upon request.

Gray shaded represent comparisons of “classic” models.

Designer/ Signature	Model No.	Outside Cup dia.	Inside Cup dia.	Cup Depth	Drill Venturi	Length	Rim	Comparison only
***	7CW	1.095 in. 27.81 mm	0.668 in. 16.97 mm	0.480 in. 12.19 mm	0.144 in. 3.66 mm	3.450 in. 87.63 mm	Medium Round	Bach 7CW
Bob Senescu	E1	1.073 in. 27.25 mm	0.689 in. 17.50 mm	0.474 in. 12.04 mm	0.144 in. 3.66 mm	3.450 in. 87.63 mm	Medium Flat	Bach 11/2 C
***	6C	1.055 in. 26.80 mm	0.664 in. 16.87 mm	0.473 in. 12.01 mm	0.147 in. 3.73 mm	3.450 in. 87.63 mm	Medium Round	Bach 6C
***	11/4C	1.082 in. 27.48 mm	0.687 in. 17.45 mm	0.457 in. 11.61 mm	0.144 in. 3.66 mm	3.450 in. 87.63 mm	Medium Round	Bach 11/4 C
Roy Roman	E1.7	1.077 in. 27.36 mm	0.715 in. 18/16 mm	0.444 in. 11.28 mm	0.144 in. 3.66 mm	3.450 in. 87.63 mm	Medium Round	Bach 1E
Jean P. Michelou	E2	1.081 in. 27.46 mm	0.689 in. 17.50 mm	0.437 in. 11.10 mm	0.150 in. 3.81 mm	3.450 in. 87.63 mm	Medium Flat	Bach 3C
***	E3/3C	1.081 in. 27.46 mm	0.677 in. 17.20 mm	0.430 in. 10.92 mm	0.140 in. 3.56 mm	3.450 in. 87.63 mm	Medium Round	Bach 3C
J. W. Marcinkiewicz	E3.1	1.081 in. 27.47 mm	0.674 in. 17.12 mm	0.430 in. 10.92 mm	0.140 in. 3.56 mm	3.450 in. 87.63 mm	Medium Round	Bach 3E
Graham Young	E4	1.068 in. 27.13 mm	0.657 in. 16.69 mm	0.429 in. 10.90 mm	0.144 in. 3.66 mm	3.450 in. 87.63 mm	Medium Round	Bach 101/2 C
Bobby Shew #2	E5	1.060 in. 26.92 mm	0.662 in. 16.81 mm	0.427 in. 10.85 mm	0.144 in. 3.66 mm	3.450 in. 87.63 mm	Medium Round	Gardinelli 10S
Herb Alpert	E6	1.056 in. 26.82 mm	0.674 in. 17.12 mm	0.425 in. 10.80 mm	0.144 in. 3.66 mm	3.450 in. 87.63 mm	Medium Round	Bach 7B
Joseph W. Marcinkiewicz	E7	1.070 in. 27.18 mm	0.674 in. 17.12 mm	0.419 in. 10.64 mm	0.140 in. 3.56 mm	3.450 in. 87.63 mm	Medium Round	Bach 3E
Rick Baptist	E8	1.105 in. 28.07 mm	0.668 in. 16.97 mm	0.419 in. 10.64 mm	0.140 in. 3.56 mm	3.450 in. 87.63 mm	Medium Round	101/2 C Shallow

593 S.E 1st Avenue • Canby, Oregon 97013

Ph. 503-263-2456

Fax 503-263-2484

email:mmpco@teleport.com



Gray shaded represent comparisons of “classic” models.

Designer/ Signature	Model No.	Outside Cup dia.	Inside Cup dia.	Cup Depth	Drill Venturi	Length	Rim	Comparison only
Manny Klein	E9	1.072 in. 27.23 mm	0.682 in. 17.32 mm	0.396 in. 10.06 mm	0.144 in. 3.66 mm	3.450 in. 87.63 mm	Medium Round	Schilke 14A4A
Bobby Shew 1.5	E9.1	1.057 in. 26.85 mm	0.662 in. 16.81 mm	0.395 in. 10.03 mm	0.140 in. 3.56 mm	3.450 in. 87.63 mm	Medium Round	Gardinelli 10S
Bob Findley	E10	1.083 in. 27.51 mm	0.687 in. 17.22 mm	0.381 in. 9.68 mm	0.140 in. 3.56 mm	3.450 in. 87.63 mm	Medium Flat	Proviance 4*3
Bobby Shew 1.25	E10.3	1.057 in. 26.85 mm	0.662 in. 16.81 mm	0.380 in. 9.65 mm	0.140 in. 3.56 mm	3.450 in. 87.63 mm	Medium Round	Gardinelli 10S
Jeff Tyzik	E11	1.080 in. 27.43 mm	0.670 in. 17.02 mm	0.378 in. 9.60 mm	0.140 in. 3.56 mm	3.450 in. 87.63 mm	Medium Round	Bach 101/2C
Allen Vizzutti	E12	1.085 in. 27.56 mm	0.670 in. 17.02 mm	0.374 in. 9.50 mm	0.140 in. 3.56 mm	3.450 in. 87.63 mm	Medium Round	Bach 101/2C
Mike Vax #1	E12.2	1.065 in. 27.05 mm	0.654 in. 16.61 mm	0.373 in. 9.47 mm	0.144 in. 3.66 mm	3.450 in. 87.63 mm	Medium Flat	Schilke 13A4A
Roger Ingram	E12.4	1.057 in. 26.85 mm	0.651 in. 16.54 mm	0.373 in. 9.47 mm	0.140 in. 3.56 mm	3.450 in. 87.63 mm	Medium Round	Bobby Shew Gardinelli
Chuck Findley	E13	1.091 in. 27.71 mm	0.681 in. 17.30 mm	0.372 in. 9.45 mm	0.140 in. 3.56 mm	3.450 in. 87.63 mm	Medium Flat	Proviance 4*3
Bobby Shew 1	E14	1.057 in. 26.85 mm	0.662 in. 16.81 mm	0.370 in. 9.40 mm	0.140 in. 3.56 mm	3.450 in. 87.63 mm	Medium Round	Gardinelli 10S
Paul Cacia	E14.1	1.065 in. 27.05 mm	0.654 in. 16.61 mm	0.369 in. 9.37 mm	0.144 in. 3.66 mm	3.450 in. 87.63 mm	Medium Flat	Schilke 13A4A
John Rinaldo	E15	1.060 in. 26.92 mm	0.650 in. 16.51 mm	0.368 in. 9.35 mm	0.147 in. 3.73 mm	3.450 in. 87.63 mm	Medium Round	Bach 101/2C
Pete Candoli	E16	1.090 in. 27.69 mm	0.608 in. 15.44 mm	0.364 in. 9.25 mm	0.140 in. 3.56 mm	3.450 in. 87.63 mm	Wide Round	Smaller than Schilke 13A4A
Bob O'Donnell	E17	1.071 in. 27.20 mm	0.644 in. 16.36 mm	0.363 in. 9.22 mm	0.147 in. 3.73 mm	3.450 in. 87.63 mm	Medium Round	Bach 101/2C Shallow
Eric Miyashiro	E18	1.084 in. 26.56 mm	0.645 in. 15.80 mm	0.361 in. 8.84 mm	0.147 in. 3.73 mm	3.450 in. 87.63 mm	Medium Flat	Schilke 13A4A
***	G10S	1.070 in. 27.18 mm	0.668 in. 16.97 mm	0.353 in. 8.97 mm	0.140 in. 3.56 mm	3.450 in. 87.63 mm	Medium Round	Gardinelli 10S
***	G10SW	1.095 in. 27.81 mm	0.668 in. 16.97 mm	0.353 in. 16.97 mm	0.140 in. 3.56 mm	3.450 in. 87.63 mm	Medium Round	Gardinelli 10S

“I recently changed to your Al Vizzutti (E12) mouthpiece. It is great! I didn't think I'd be able to handle a large inner diameter like this, but I adapted immediately and had no down time. Articulation, quality of sound, and general ease of playing improved at once, along with getting a very strong lead trumpet sound. I am also able to get a very warm, rich relaxed sound for jazz playing. It is great to get all (these sounds) on one mouthpiece.”

-Paul Von Adam,

Kenton Band Alum, Conductor, Educator,
Accomplished big band, show, recording, TV and
commercial Trumpet Player -Brandon, FL

593 S.E 1st Avenue • Canby, Oregon 97013

Ph. 503-263-2456

Fax 503-263-2484

email:mmpco@teleport.com

The “300” Series Trumpet Mouthpieces

Important Educator Information



15 Graduated Cup Depths on Same Rim

Tool for Educators

Solution for Students

As a woodwind player's embouchure becomes more developed, the necessary strength of the reed will change from weak to strong. If students use a reed that is too hard or too soft, they will have trouble playing certain notes. Woodwind players have always had a logical choice of reeds to help them make the proper choice for their playing needs. Now the same holds true for developing brass players, and their selection of appropriate mouthpieces. Like woodwind players, brass players' embouchures develop with experience and time. After discussing this problem with numerous educators, our “300” Series was developed not only for the student, but as a **tool for the educator**, to resolve real problems for growing students.

Developed specifically with the student in mind, (although many professionals use them as well), these mouthpieces offer the same rim (similar to a 3C *) on 15 different cup depths, graduated at .006 in. intervals, (the equivalent to the thickness of two human hairs.), from deepest (No.301) to shallowest (No.315), allowing the developing player to find optimal response from a mouthpiece with the same rim. For example, if a No.307 is too deep and a No.312 too shallow, the No.309 or No.310 may be the appropriate fit. Please note: No.300 has the same cup depth as the No.301 with an expanded cup diameter.

As players mature, their needs change. This series allows selection to the next logical cup depth, while maintaining the exact rim dimensions of the previous choice. The result is a mouthpiece that both feels good to the player and provides the desired sound instantly, without a frustrating transition.

The line also includes an “ S” (symphonic) backbone. The benefit to the player is a richer, darker tone associated with concert bands and orchestras.

*** This rim was determined by comparing and testing many 3C mouthpieces for comfort and best attributes.**

“Just wanted to let you know, I think Marcinkiewicz Mouthpieces are truly the best available today. After 40 years of playing I never thought I'd find a mouthpiece with such superior TONE, COMFORT, SUPPORT and FREE BLOWING. I cannot believe the difference in my playing.”

“ My students are receiving the same benefits from your product as I am. The difference is immediate. Most seem to benefit most from something in the '300 Series'. It is very rewarding to see the look on the face of a struggling student, who is fit properly, discovering the ease of play of one of your mouthpieces. Thanks!”

-Joe L. Luna, Trumpet Player and Private Instructor - San Diego, CA

593 S.E 1st Avenue • Canby, Oregon 97013

Ph. 503-263-2456

Fax 503-263-2484

email:mmpco@teleport.com

The "300" Series Trumpet Mouthpieces



Trumpet Model No.	Outside Cup dia.	Inside Cup dia.	Cup Depth	Drill Venturi	Length	Rim	Comparison only
300	1.090 in. 27.69 mm	0.692 in. 17.58 mm	0.513 in. 13.03 mm	0.144 in. 3.66 mm	3.450 in. 87.63 mm	Medium Round	Bach B Cup
301	1.081 in. 27.46 mm	0.677 in. 17.20 mm	0.513 in. 13.03 mm	0.144 in. 3.66 mm	3.450 in. 87.63 mm	Medium Round	Bach B Cup
302	1.081 in. 27.46 mm	0.677 in. 17.20 mm	0.507 in. 12.88 mm	0.144 in. 3.66 mm	3.450 in. 87.63 mm	Medium Round	Bach B Cup
303	1.081 in. 27.46 mm	0.677 in. 17.20 mm	0.501 in. 12.73 mm	0.144 in. 3.66 mm	3.450 in. 87.63 mm	Medium Round	Bach B Cup
304	1.081 in. 27.46 mm	0.677 in. 17.20 mm	0.495 in. 12.57 mm	0.144 in. 3.66 mm	3.450 in. 87.63 mm	Medium Round	Bach B Cup
305	1.081 in. 27.46 mm	0.677 in. 17.20 mm	0.489 in. 12.42 mm	0.144 in. 3.66 mm	3.450 in. 87.63 mm	Medium Round	Bach B Cup
306	1.081 in. 27.46 mm	0.677 in. 17.20 mm	0.483 in. 12.27 mm	0.144 in. 3.66 mm	3.450 in. 87.63 mm	Medium Round	Bach C Cup
307	1.081 in. 27.46 mm	0.677 in. 17.20 mm	0.477 in. 12.12 mm	0.144 in. 3.66 mm	3.450 in. 87.63 mm	Medium Round	Bach C Cup
308/1 1/2 C	1.081 in. 27.46 mm	0.677 in. 17.20 mm	0.471 in. 11.96 mm	0.144 in. 3.66 mm	3.450 in. 87.63 mm	Medium Round	Bach C Cup
309	1.081 in. 27.46 mm	0.677 in. 17.20 mm	0.465 in. 11.81 mm	0.144 in. 3.66 mm	3.450 in. 87.63 mm	Medium Round	Bach C Cup
310	1.081 in. 27.46 mm	0.677 in. 17.20 mm	0.459 in. 11.66 mm	0.144 in. 3.66 mm	3.450 in. 87.63 mm	Medium Round	Bach C Cup
311	1.081 in. 27.46 mm	0.677 in. 17.20 mm	0.453 in. 11.51 mm	0.144 in. 3.66 mm	3.450 in. 87.63 mm	Medium Round	Bach E Cup
312	1.081 in. 27.46 mm	0.677 in. 17.20 mm	0.447 in. 11.35 mm	0.144 in. 3.66 mm	3.450 in. 87.63 mm	Medium Round	Bach E Cup
313	1.081 in. 27.46 mm	0.677 in. 17.20 mm	0.441 in. 11.20 mm	0.144 in. 3.66 mm	3.450 in. 87.63 mm	Medium Round	Bach E Cup
314	1.081 in. 27.46 mm	0.677 in. 17.20 mm	0.435 in. 11.05 mm	0.144 in. 3.66 mm	3.450 in. 87.63 mm	Medium Round	Bach E Cup
315	1.081 in. 27.46 mm	0.677 in. 17.20 mm	0.429 in. 10.90 mm	0.144 in. 3.66 mm	3.450 in. 87.63 mm	Medium Round	Bach E Cup

593 S.E 1st Avenue • Canby, Oregon 97013

Ph. 503-263-2456

Fax 503-263-2484

email:mmpco@teleport.com

Pro-Line Concert Hall™ Trumpet/Cornet/Flugelhorn Mouthpieces (pat. Pending)

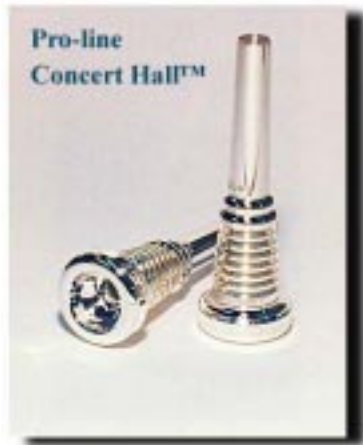

*Dark
Symphonic
Sound*

Designed for the player whose needs are not met elsewhere, these mouthpieces affords enhanced projection, even timbre from ppp to fff, and the same great intonation throughout all registers that Marcinkiewicz mouthpieces are famous for.

Pro-Line Concert Hall™ mouthpieces have a unique exterior design that offers optimal nodal enhancement by placing integral vibration dampers in specific, calculated areas. The net result is a mouthpiece that gives an extremely stable center of pitch, allows unprecedented dynamic levels without distortion and provides a rich, dark symphonic sound without the additional mass of a conventional heavy wall mouthpiece.

Pro-Line Concert Hall™ mouthpieces can be custom fitted to suit your needs.

Pro-Line Concert Hall™ mouthpieces are optimized to give the player the best efficiency possible without compromise.

All Pro-Line Concert Hall™ mouthpieces are special order and custom work is available upon request. They are optimized for Bb trumpets, but will function on cornet, flugelhorn and other keyed instruments.

Pro-Line Concert Hall™ Model No.	Outside Cup dia.	Inside Cup dia.	Cup Depth	Drill Venturi	Length	Rim	Comparison only
A1	1.090 in. 27.69 mm	0.692 in. 17.58 mm	0.513 in. 13.03 mm	0.149 in. 3.78 mm	3.450 in. 87.63 mm	Medium Round	Bach 1B Monette B1-1
A3	1.090 in. 27.69 mm	0.692 in. 17.58 mm	0.501 in. 12.73 mm	0.149 in. 3.78 mm	3.450 in. 87.63 mm	Medium Round	Bach 1 Stork 1
A5	1.090 in. 27.69 mm	0.692 in. 17.58 mm	0.489 in. 12.42 mm	0.149 in. 3.78 mm	3.450 in. 87.63 mm	Medium Round	Bach 1C Monette B1-5
B1	1.082 in. 27.48 mm	0.687 in. 17.45 mm	0.513 in. 13.03 mm	0.149 in. 3.78 mm	3.450 in. 87.63 mm	Medium Round	Bach 1X Stork 2B
B3	1.082 in. 27.48 mm	0.687 in. 17.45 mm	0.501 in. 12.73 mm	0.149 in. 3.78 mm	3.450 in. 87.63 mm	Medium Round	Bach 1 1/4 C Monette B2
B5	1.082 in. 27.48 mm	0.687 in. 17.45 mm	0.489 in. 12.42 mm	0.149 in. 3.78 mm	3.450 in. 87.63 mm	Medium Round	Bach 1 1/2 C Stork 2C
C1	1.081 in. 27.46 mm	0.677 in. 17.20 mm	0.513 in. 13.03 mm	0.149 in. 3.78 mm	3.450 in. 87.63 mm	Medium Round	Stork 3B Monette B4
C3	1.081 in. 27.46 mm	0.677 in. 17.20 mm	0.501 in. 12.73 mm	0.149 in. 3.78 mm	3.450 in. 87.63 mm	Medium Round	Bach 3 Monette B5
C5	1.081 in. 27.46 mm	0.677 in. 17.20 mm	0.489 in. 12.42 mm	0.149 in. 3.78 mm	3.450 in. 87.63 mm	Medium Round	Bach 3C Monette B6

593 S.E 1st Avenue • Canby, Oregon 97013

Ph. 503-263-2456

Fax 503-263-2484

email:mmpco@teleport.com

Cornet Mouthpieces



Rich Cornet Sound

The rims and cups in the Standard and the “300” Series cornet line are identical to those in the trumpet line with the same number*. A No.4/7C trumpet mouthpiece has the identical rim and cup as a No. 4/7C cornet mouthpiece. Please note, the cornet mouthpieces have a larger throat (#26), which allows more air through the instrument for a darker, richer cornet sound. The No.0 to No.15 are also offered with an "S" (symphonic) backbore.

These mouthpieces are also numbered in the logical deep to shallow progression to offer optimum choice.

**Any Designer / Signature model in cornet is a special order custom mouthpiece.*

Cornet Model No.	Outside Cup dia.	Inside Cup dia.	Cup Depth	Drill Venturi	Length	Rim	Comparison only
0-15, O-S, 15-S	SAME	AS	TRUMPET	0.147 in. 3.73 mm	2.800 in. 71.12 mm	Medium Round	Same as Trumpet
300 - 315	SAME	AS	TRUMPET	0.147 in. 3.73 mm	2.800 in. 71.12 mm	Medium Round	Same as Trumpet
5*W	1.045 in. 26.54 mm	0.660 in. 16.76 mm	0.628 in. 15.95 mm	0.154 in. 3.91 mm	2.450 in. 62.23 mm	Medium Round	Dennis Wick 5
5XW	1.065 in. 27.05 mm	0.680 in. 17.27 mm	0.628 in. 15.95 mm	0.154 in. 3.91 mm	2.450 in. 62.23 mm	Medium Round	D. Wick 5 Expanded Rim
4 *W	1.045 in. 26.54 mm	0.676 in. 17.17 mm	0.531 in. 13.49 mm	0.166 in. 4.22 mm	2.450 in. 62.23 mm	Medium Round	Dennis Wick 4
7CW	1.095 in. 27.81 mm	0.668 in. 16.97 mm	0.480 in. 12.19 mm	0.147 in. 3.73 mm	2.800 in. 71.12 mm	Medium Round	Bach 7CW
11/4C	1.080 in. 27.48	0.687 in. 17.45 mm	0.457 in. 11.61	0.147 in. 3.73 mm	2.800 in. 71.12 mm	Medium Round	Bach 11/4C
3C	1.081 in. 27.46 mm	0.677 in. 17.20 mm	0.430 in. 10.92 mm	0.147 in. 3.73 mm	2.800 in. 71.12 mm	Medium Round	Bach 3C

“I purchased an E3/3C from you recently. I love it”

“I have a 1/5B and I really love it too. I think you make one of the finest products out there, and I've played them all. Keep making a product that I can always rely on.”

Phil Aucutt, Trumpet Player, University of Wisconsin Marching Band - Madison, WI

593 S.E 1st Avenue • Canby, Oregon 97013

Ph. 503-263-2456

Fax 503-263-2484

email:mmpco@teleport.com

Flugelhorn Mouthpieces



Choice in Size and Sound

The rim contours of our flugelhorn mouthpieces No.3FL(B/D), No.5FL(B/D) and No.7FL(B/D) are similar to our standard trumpet line. FLB designations indicates Bright and FLD indicates Dark. The No.3FLS, No.5FLS and No.7FLS are designed for a players that need more lip (chops) room. The "300" series (No.303FL, No.305FL and No.307FL) is our largest flugelhorn mouthpieces series and has the same rim as the Student "300" Series trumpet mouthpieces, allowing the player to use the same rim on trumpet and flugelhorn. Please keep in mind the No.3, No.5, and No.7 are logically numbered from largest to smallest in depth.

We also offer models BSFL and BSC FL (Cuenon shank) . The BSFL and BSC FL are not directly related to the E5, E9.1,E10.3 or E14 trumpet mouthpieces.

All flugelhorn Models (except BSC FL) have a standard flugelhorn shank. Cuenon shanked mouthpieces are available by special order.

**Any Designer/Signature model in flugelhorn is a special order custom mouthpiece*

Flugelhorn Model No.	Outside Cup dia.	Inside Cup dia.	Cup Depth	Drill Venturi	Length	Rim	Comparison only
3FLB	1.070 in. 27.18 mm	0.679 in. 17.25 mm	0.547 in. 13.89 mm	0.161 in. 4.09 mm	2.750 in. 69.85 mm	Medium Round	Bach 3FL
3FLD	1.070 in. 27.18 mm	0.679 in. 17.25 mm	0.547 in. 13.89 mm	0.170 in. 4.32 mm	2.750 in. 69.85 mm	Medium Round	Bach 3FL
5FLB	1.069 in. 27.15 mm	0.679 in. 17.25 mm	0.517 in. 13.13 mm	0.161 in. 4.09 mm	2.750 in. 69.85 mm	Medium Round	Bach 5FL
5FLD	1.069 in. 27.15 mm	0.679 in. 17.25 mm	0.517 in. 13.13 mm	0.170 in. 4.32 mm	2.750 in. 69.85 mm	Medium Round	Bach 5FL
7FLB	1.068 in. 27.13 mm	0.679 in. 17.25 mm	0.474 in. 12.04 mm	0.161 in. 4.09 mm	2.750 in. 69.85 mm	Medium Round	Bach 7FL
7FLD	1.068 in. 27.13 mm	0.679 in. 17.25 mm	0.474 in. 12.04 mm	0.170 in. 4.32 mm	2.750 in. 69.85 mm	Medium Round	Bach 7FL
3FLS	1.070 in. 27.18 mm	0.706 in. 17.93 mm	0.537 in. 13.64 mm	0.173 in. 4.39 mm	2.750 in. 69.85 mm	Medium Round	Bach 3FL
5FLS	1.069 in. 27.15 mm	0.706 in. 17.93 mm	0.509 in. 12.93 mm	0.173 in. 4.39 mm	2.750 in. 69.85 mm	Medium Round	Bach 5FL
7FLS	1.068 in. 27.13 mm	0.706 in. 17.93 mm	0.481 in. 12.22 mm	0.173 in. 4.39 mm	2.750 in. 69.85 mm	Medium Round	Bach 7FL
303FL	1.081 in. 27.46 mm	0.677 in. 17.20 mm	0.537 in. 13.64 mm	0.170 in. 4.32 mm	2.750 in. 69.85 mm	Medium Round	***
305FL	1.081 in. 27.46 mm	0.677 in. 17.20 mm	0.509 in. 12.93 mm	0.170 in. 4.32 mm	2.750 in. 69.85 mm	Medium Round	***
307FL	1.081 in. 27.46 mm	0.677 in. 17.20 mm	0.481 in. 12.22 mm	0.170 in. 4.32 mm	2.750 in. 69.85 mm	Medium Round	***
BS FL	1.062 in. 26.97 mm	0.659 in. 16.74 mm	0.626 in. 15.90 mm	0.173 in. 4.39 mm	2.860 in. 72.64 mm	Medium Round	Bobby Shew Model
BSC FL	1.062 in. 26.97 mm	0.659 in. 16.74 mm	0.626 in. 15.90 mm	0.173 in. 4.39 mm	2.860 in. 72.64 mm	Medium Round	Bobby Shew Cuenon

593 S.E 1st Avenue • Canby, Oregon 97013

Ph. 503-263-2456

Fax 503-263-2484

email:mmpco@teleport.com

French Horn Mouthpieces and Venturi Chart



Innovative Design

Our French Horn Mouthpieces are of a unique design, and are played by some of the most discerning horn players. These mouthpieces are numbered in a logical progression from wide to narrow and deep to shallow. These are some of the finest mouthpieces made in the world today and stand alone as such.

These mouthpieces are also available an "S" (symphonic) backbore.

F. H. Model No.	Outside Cup dia.	Inside Cup dia.	Cup Depth	Drill Venturi	Length	Rim	Comparison only
1	1.000 in. 25.40 mm	0.705 in. 17.91 mm	1.006 in. 25.55 mm	0.228 in. 5.79 mm	2.500 in. 63.50 mm	Round	Schilke 32
3	1.000 in. 25.40 mm	0.705 in. 17.91 mm	0.992 in. 25.20 mm	0.213 in. 5.41 mm	2.500 in. 63.50 mm	Round	Giardinelli C4
5	1.000 in. 25.40 mm	0.699 in. 17.75 mm	0.983 in. 24.97 mm	0.206 in. 5.23 mm	2.500 in. 63.50 mm	Round	Smaller than C4
7	1.000 in. 25.40 mm	0.699 in. 17.75 mm	0.974 in. 24.74 mm	0.201 in. 5.11 mm	2.500 in. 63.50 mm	Round	Larger than C10
9	1.000 in. 25.40 mm	0.692 in. 17.58 mm	0.965 in. 24.51 mm	0.196 in. 4.98 mm	2.500 in. 63.50 mm	Round	Giardinelli C10
11	1.000 in. 25.40 mm	0.692 in. 17.58 mm	0.956 in. 24.28 mm	0.191 in. 4.85 mm	2.500 in. 63.50 mm	Round	Holton Farkas MDC
13	1.000 in. 25.40 mm	0.686 in. 17.42 mm	0.947 in. 24.50 mm	0.185 in. 4.70 mm	2.500 in. 63.50 mm	Round	Bach 7

In our French Horn mouthpiece line, the number of the mouthpiece equals number of the reamer (venturi) size.

Trumpet, Cornet, Flugelhorn	Trombone	Tuba
0.140 in.=28	0.228 in.=1	0.302 in.=N
(0.1405 in.)	0.234 in.=A	0.316 in.=O
0.144 in.=27	0.246 in.=D	0.323 in.=P
0.147 in.=26	0.250 in.=E	0.328 in.=21/64
0.149 in.=25	0.257 in.=F	0.348 in.=S
0.152 in.=24	0.261 in.=G	
0.154 in.=23	0.266 in.=H	
0.161 in.=20	0.281 in.=K	
0.166 in.=19	0.290 in.=L	
0.170 in.=18		
0.173 in.=17		

Please note that we use reamers to manufacture our venturies. We do not use drill bits.

“ Drills can be used for determining Approximate size, but are inadequate for manufacturing or modifying any mouthpieces.”-J.M.

593 S.E 1st Avenue • Canby, Oregon 97013

Ph. 503-263-2456

Fax 503-263-2484

email:mmpco@teleport.com

Trombone, Euphonium, & Bass Trombone Mouthpieces



Real Choice In Size

Our standard trombone and euphonium mouthpieces are arranged on our specification chart in a logical ascending order from deep to shallow, No.5GW to No.15 in tenor, No.1 to No.8H B.S. / 61/2AL in bass and No.5G-S to 7G-S in Euphonium/Baritone. As rim size does not directly correspond to cup depth, please observe inside cup diameter for finding optimal response.

The comparison column on this chart (and all charts in the catalog) offers rough comparisons only. The comparisons are given for casual references only.

Please note all Euphonium/Baritone mouthpieces come with an "S" (symphonic) backbore. "S" (symphonic) backbores available in Tenor and Bass Trombone mouthpieces on special order.

Gray shaded areas represent comparisons of "classic" models.

Tenor Trombone Model No.	Outside Cup dia.	Inside Cup dia.	Cup Depth	Drill Venturi	Length	Comparison only
5GW Greg Woll	1.538 in. 39.07 mm	1.006 in. 25.55 mm	1.150 in. 29.21 mm	0.261 in. 29.21 mm	3.250 in. 82.55 mm	Bach 5GW
5G	1.538 in. 39.07 mm	1.006 in. 25.55 mm	1.150 in. 29.21 mm	0.261 in. 6.63 mm	3.170 in. 80.52 mm	Bach 5G
9B Bob Stroup	1.545 in. 39.24 mm	1.026 in. 26.06 mm	1.091 in. 27.71 mm	0.250 in. 6.35 mm	3.140 in. 79.76 mm	Bach 5
5F	1.534 in. 38.96 mm	1.015 in. 25.78 mm	1.083 in. 27.51 mm	0.257 in. 6.53 mm	3.170 in. 80.52 mm	3.170 in. 80.52 mm
8H/61/2 AL	1.534 in. 38.96 mm	1.026 in. 26.06 mm	1.047 in. 26.59 mm	0.266 in. 6.76 mm	3.170 in. 80.52 mm	Bach 61/2 AL
6E	1.534 in. 38.96 mm	1.015 in. 25.78 mm	1.045 in. 26.54 mm	0.250 in. 6.35 mm	3.170 in. 80.52 mm	Bach 3
7G	1.534 in. 38.96 mm	1.015 in. 25.78 mm	0.996 in. 25.30 mm	0.261 in. 6.63 mm	3.170 in. 80.52 mm	Bach 3
8	1.534 in. 38.96 mm	1.021 in. 25.93 mm	0.995 in. 25.27 mm	0.261 in. 6.63 mm	3.170 in. 80.52 mm	Bach 4
9	1.545 in. 39.24 mm	1.026 in. 26.06 mm	0.976 in. 24.79 mm	0.250 in. 6.35 mm	3.170 in. 80.52 mm	Bach 61/2AL
10	1.530 in. 38.86 mm	0.999 in. 25.37 mm	0.939 in. 23.85 mm	0.234 in. 5.94 mm	3.170 in. 80.52 mm	Bach 7C
11	1.530 in. 38.86 mm	1.000 in. 25.40 mm	0.907 in. 23.04 mm	0.234 in. 5.94 mm	3.170 in. 80.52 mm	Bach 11C
12	1.500 in. 38.10 mm	0.988 in. 25.10 mm	0.889 in. 22.58 mm	0.234 in. 5.94 mm	3.170 in. 80.52 mm	Bach 12C
11C	1.520 in. 38.61 mm	0.999 in. 25.37 mm	0.868 in. 22.05 mm	0.234 in. 5.94 mm	3.170 in. 80.52 mm	Bach 11C
7C	1.495 in. 37.97 mm	0.989 in. 25.12 mm	0.867 in. 22.02 mm	0.234 in. 5.94 mm	3.170 in. 80.52 mm	Bach 7C
12C	1.500 in. 38.10 mm	0.988 in. 25.10 mm	0.806 in. 20.47 mm	0.234 in. 5.94 mm	3.170 in. 80.52 mm	Bach 12C
15	1.500 in. 38.10 mm	0.988 in. 25.10 mm	0.806 in. 20.47 mm	0.234 in. 5.94 mm	3.170 in. 80.52 mm	Bach 15C

Specify type of shank when ordering * Note: Tenor Trombone models are available in bass shank upon special order.

593 S.E 1st Avenue • Canby, Oregon 97013

Ph. 503-263-2456

Fax 503-263-2484

email:mmpco@teleport.com

Trombone, Euphonium, & Bass Trombone Mouthpieces



Because euphonium mouthpiece receivers vary, please specify manufacturer of euphonium when ordering.

Euphonium Model No.	Outside Cup dia.	Inside Cup dia.	Cup Depth	Drill Venturi	Length	Comparison only
5G-S	1.538 in. 39.07 mm	1.006 in. 25.55 mm	1.150 in. 29.21 mm	0.261 in. 6.63 mm	3.170 in. 80.52 mm	Bach 5GS
9B-S	1.545 in. 39.24 mm	1.026 in. 26.06 mm	1.091 in. 27.71 mm	0.250 in. 6.35 mm	3.140 in. 79.76 mm	Bach 5
5F-S	1.534 in. 38.96 mm	1.015 in. 25.78 mm	1.083 in. 27.51 mm	0.257 in. 6.53 mm	3.170 in. 80.52 mm	Bach 3
8H-S	1.534 in. 38.96 mm	1.026 in. 26.06 mm	1.047 in. 26.59 mm	0.266 in. 6.76 mm	3.170 in. 80.52 mm	Bach 6 1/2 AL
6E-S	1.534 in. 38.96 mm	1.015 in. 25.78 mm	1.045 in. 26.54 mm	0.250 in. 6.35 mm	3.170 in. 80.52 mm	Bach 3
7G-S	1.534 in. 38.96 mm	1.015 in. 25.78 mm	0.996 in. 25.30 mm	0.261 in. 6.63 mm	3.170 in. 80.52 mm	Bach 3

Gray shaded areas represent comparisons of "classic models"

Bass Trombone Model No.	Outside Cup dia.	Inside Cup dia.	Cup Depth	Drill Venturi	Length	Comparison only
1	1.540 in. 39.12 mm	1.110 in. 28.19 mm	1.238 in. 31.45 mm	0.281 in. 7.14 mm	3.170 in. 80.52 mm	1 1/2 G Oversized
1 1/2	1.540 in. 39.12 mm	1.096 in. 27.84 mm	1.203 in. 30.56 mm	0.281 in. 7.14 mm	3.170 in. 80.52 mm	Bach 1 1/2 G
3	1.540 in. 39.12 mm	1.096 in. 27.84 mm	1.153 in. 29.29 mm	0.281 in. 7.14 mm	3.170 in. 80.52 mm	Bach 2
5G	1.538 in. 39.07 mm	1.006 in. 25.55 mm	1.150 in. 29.21 mm	0.261 in. 6.63 mm	3.170 in. 80.52 mm	Bach 5G
8H B.S./61/2AL	1.534 in. 38.96 mm	1.026 in. 26.06 mm	1.047 in. 26.59 mm	0.266 in. 6.76 mm	3.170 in. 80.52 mm	Bach 61/2 AL

Specify type of shank when ordering.

"I am auditioning a Marcinkiewicz ET-3 Charlie Loper tenor trombone mouthpiece. I am writing to tell you it is one of the best (if not the best) trombone mouthpieces I have ever had the pleasure of playing. The response is quite even and open in all registers. The high register is very focused without getting inappropriately bright. You have a wonderful product for the brass playing community."

- Eric Richards, Trombone Player - Crownsville, MD

593 S.E 1st Avenue • Canby, Oregon 97013

Ph. 503-263-2456

Fax 503-263-2484

email:mmpco@teleport.com

Designer/Signature Trombone & Bass Trombone Mouthpieces



Designed for Demanding Situations

These mouthpieces are made to each specific player's specifications. Measurements such as inner diameter, venturi, etc., are not arranged systematically, however this line is also numbered progressively by cup depth from deep to shallow.

Each of our endorsees chose a Marcinkiewicz Designer/Signature Mouthpiece because of their belief in the product. Each of these mouthpieces were designed for a specific player at a specific point in time. Many play Marcinkiewicz mouthpieces exclusively.

Gray shaded areas represent comparisons of "classic" models.

Tenor Trombone Designer/Signature	Model No.	Outside Cup dia.	Inside Cup dia.	Cup Depth	Drill Venturi	Length	Comparison only
Byron Peebles	ET1	1.494 in. 37.95 mm	1.029 in. 26.14 mm	1.156 in. 29.36 mm	0.266 in. 6.76 mm	3.170 in. 80.52 mm	Bach 5G bass shank
Jiggs Whigham	ET1.7	1.495 in. 37.97 mm	0.988 in. 25.10 mm	0.895 in. 22.73 mm	0.234 in. 5.94 mm	.250 in. 82.55 mm	***
Ian McDougall	ET2	1.520 in. 38.61 mm	0.999 in. 25.37 mm	0.868 in. 22.05 mm	0.228 in. 5.79 mm	3.140 in. 79.76 mm	N. Y. Bach 11C
Charlie Loper	ET3	1.514 in. 38.46 mm	0.988 in. 25.10 mm	0.856 in. 21.74 mm	0.234 in. 5.94 mm	3.140 in. 79.76 mm	Mt. Vernon Bach 11C
Lloyd Ulyate	ET4	1.487 in. 37.77 mm	0.989 in. 25.12 mm	0.867 in. 22.02 mm	0.246 in. 6.25 mm	3.030 in. 76.96 mm	N.Y.Bach 12C
David Steinmeyer	ET7	1.561 in. 39.65 mm	0.981 in. 24.92 mm	0.761 in. 19.33 mm	0.228 in. 5.79 mm	3.140 in. 79.76 mm	Bach 18

Bass Trombone Designer/Signature	Model No.	Outside Cup dia.	Inside Cup dia.	Cup Depth	Drill Venturi	Length	Comparison only
Bill Rickenbach	EBT1	1.551 in. 39.40 mm	1.131 in. 28.73 mm	1.225 in. 31.12 mm	0.290 in. 7.37 mm	3.200 in. 81.28 mm	Bach 11/2 G Oversized
Phil Teele	EBT2	1.540 in. 39.12 mm	1.125 in. 28.58 mm	1.220 in. 30.99 mm	0.281 in. 7.14 mm	3.200 in. 81.28 mm	Bach 11/2 G
Ernie Tack	EBT3	1.540 in. 39.12 mm	1.116 in. 28.35 mm	1.178 in. 29.92 mm	0.281 in. 7.14 mm	3.170 in. 80.52 mm	Bach 11/2 G
***	105	1.680 in. 42.67 mm	1.159 in. 29.44 mm	1.343 in. 34.11 mm	0.316 in. 8.03 mm	3.500 in. 88.90 mm	Schilke 60 Kleinhammer
Jim Martin	106	1.670 in. 42.42 mm	1.184 in. 30.07 mm	1.384 in. 35.15 mm	0.316 in. 8.03 mm	3.500 in. 88.90 mm	Schilke 60
***	107	1.680 in. 42.67 mm	1.187 in. 30.15 mm	1.383 in. 35.13 mm	0.316 in. 8.03 mm	3.500 in. 88.90 mm	Schilke 60 C. Vernon

***We consider no.105, 106 and 107 to be contrabass trombone mouthpieces.

593 S.E 1st Avenue • Canby, Oregon 97013

Ph. 503-263-2456

Fax 503-263-2484

email:mmpco@teleport.com

Pro-Line Concert Hall™ (pat. pending) Tenor/Bass Trombone, Euphonium Mouthpieces



**Dark
Symphonic
Sound**

Designed for the player whose needs are not met elsewhere, these mouthpieces affords enhanced projection, even timbre from ppp to fff, and the same great intonation throughout all registers that Marcinkiewicz mouthpieces are famous for.

Pro-Line Concert Hall™ mouthpieces have a unique exterior design that offers optimal nodal enhancement by placing integral vibration dampers in specific, calculated areas. The net result is a mouthpiece that gives an extremely stable center of pitch, allows unprecedented dynamic levels without distortion and provides a rich, dark symphonic sound without the additional mass of a conventional heavy wall mouthpiece.

Pro-Line Concert Hall™ mouthpieces can be custom fitted to suit your needs.

Pro-Line Concert Hall™ mouthpieces are optimized to give the player the best efficiency possible without compromise.

All Pro-Line Concert Hall™ mouthpieces are special order and custom work is available upon request.

Pro-Line Concert Hall™ Model No.	Outside Cup dia.	Inside Cup dia.	Cup Depth	Drill Venturi	Length	Comparison only
Tenor Trombone						
5G	1.538 in. 39.07 mm	1.006 in. 25.55 mm	1.150 in. 29.21 mm	0.261 in. 6.63 mm	3.170 in. 80.52 mm	Bach 5G
5J	1.538 in. 39.07 mm	1.006 in. 25.55 mm	1.150 in. 29.21 mm	0.277 in. 7.04 mm	3.170 in. 80.52 mm	Bach 5G
9B	1.545 in. 39.24 mm	1.026 in. 26.06 mm	1.091 in. 27.71 mm	0.250 in. 6.35 mm	3.140 in. 79.76 mm	Bach 5
8H / 61/2 AL	1.534 in. 38.96 mm	1.026 in. 26.06 mm	1.047 in. 26.59 mm	0.266 in. 6.76 mm	3.170 in. 80.52 mm	Bach 61/2 AL
Bass Trombone						
11/2G	1.540 in. 39.22 mm	1.096 in. 27.84 mm	1.203 in. 30.56 mm	0.281 in. 7.14 mm	3.170 in. 80.52 mm	Bach 11/2 G
5G	1.538 in. 39.07 mm	1.006 in. 25.55 mm	1.150 in. 29.21 mm	0.261 in. 6.63 mm	3.170 in. 80.52 mm	Bach 5G
8H/61/2 AL	1.234 in. 38.96 mm	1.026 in. 26.03 mm	1.047 in. 26.59 mm	0.266 in. 6.76 mm	3.170 in. 80.52 mm	Bach 61/2 AL

593 S.E 1st Avenue • Canby, Oregon 97013

Ph. 503-263-2456

Fax 503-263-2484

email:mmpco@teleport.com

Tuba & Sousaphone Mouthpieces

New Visualizers



Large Selection

Our standard tuba mouthpieces are arranged in a logical ascending order from deep to shallow and wide to narrow in three different types; N, W, & H. Please note that the chart is grouped in sections according to type. This arrangement permits players to select a mouthpiece by precise increments of depth to find the correct cup volume required by their musical needs.

'N' mouthpieces have a narrow rim, 'W' pieces have a wider rim and 'H' pieces have a smaller inside bite. **The ST3 and ST4, with shallower cups, are designed specifically for students.** (It doesn't hurt to play!)

Models given for comparison again reflect standard sizes. These are not copies; substantial changes and improvements have been made to increase playability and response.

Model No.	Outside Cup dia.	Inside Cup dia.	Cup Depth	Drill Venturi	Length	Comparison only
H1	1.873 in. 47.57 mm	1.325 in. 33.60 mm	1.632 in. 41.45 mm	0.328 in. 8.33 mm	3.800 in. 96.52 mm	Conn Helleberg
H2	1.873 in. 47.57 mm	1.323 in. 33.60 mm	1.582 in. 40.18 mm	0.328 in. 8.33 mm	3.800 in. 96.52 mm	"
H3	1.873 in. 47.57 mm	1.323 in. 33.60 mm	1.532 in. 38.91 mm	0.328 in. 8.33 mm	3.800 in. 96.52 mm	"
H4	1.873 in. 47.57 mm	1.323 in. 33.60 mm	1.467 in. 37.26 mm	0.328 in. 8.33 mm	3.800 in. 96.52 mm	"
N1	1.940 in. 49.28 mm	1.325 in. 33.66 mm	1.517 in. 38.53 mm	0.302 in. 7.67 mm	3.800 in. 96.52 mm	Mirafone C3
N2	1.940 in. 49.28 mm	1.325 in. 33.66 mm	1.476 in. 37.26 mm	0.302 in. 7.67 mm	3.800 in. 96.52 mm	"
N3	1.940 in. 49.28 mm	1.325 in. 33.66 mm	1.417 in. 35.99 mm	0.302 in. 7.67 mm	3.800 in. 96.52 mm	"
T. Johnson N4	1.940 in. 49.28 mm	1.325 in. 33.66 mm	1.352 in. 34.34 mm	0.302 in. 7.67 mm	3.800 in. 96.52 mm	"
W1	1.980 in. 50.29 mm	1.325 in. 33.66 mm	1.517 in. 38.53 mm	0.302 in. 7.67 mm	3.800 in. 96.52 mm	Mirafone C4
W2	1.980 in. 50.29 mm	1.325 in. 33.66 mm	1.476 in. 37.26 mm	0.302 in. 7.67 mm	3.800 in. 96.52 mm	"
W3	1.980 in. 50.29 mm	1.325 in. 33.66 mm	1.417 in. 35.99 mm	0.302 in. 7.67 mm	3.800 in. 96.52 mm	"
W4	1.980 in. 50.29 mm	1.325 in. 33.66 mm	1.352 in. 34.34 mm	0.302 in. 7.67 mm	3.800 in. 96.52 mm	"

593 S.E 1st Avenue • Canby, Oregon 97013

Ph. 503-263-2456

Fax 503-263-2484

email:mmpco@teleport.com



Embouchure Visualizers

Model No.	Outside Cup dia.	Inside Cup dia.	Cup Depth	Drill Venturi	Length	Comparison only
Jim Self ETU 1	1.973 in. 50.11 mm	1.305 in. 33.15 mm	1.457 in. 37.01 mm	0.316 in. 8.03 mm	3.800 in. 96.52 mm	***
ST 3	1.875 in. 47.63 mm	1.277 in. 32.44 mm	1.287 in. 32.69 mm	1.287 in. 32.69 mm	1.287 in. 32.69 mm	***
ST 4	1.875 in. 47.63 mm	1.277 in. 32.44 mm	1.222 in. 31.04 mm	0.302 in. 8.33 mm	3.800 in. 96.52 mm	***
18	1.876 in. 47.65 mm	1.290 in. 32.77 mm	1.443 in. 36.65 mm	0.323 in. 8.20 mm	3.800 in. 96.52 mm	Bach 18
24AW	1.955 in. 49.66 mm	1.281 in. 32.54 mm	1.657 in. 42.09 mm	0.348 in. 8.84 mm	3.800 in. 96.52 mm	Bach 24AW
25	1.845 in. 46.86 mm	1.230 in. 31.24 mm	1.495 in. 37.97 mm	0.328 in. 8.33 mm	3.800 in. 96.52 mm	Bach 25



Our embouchure visualizers are designed to be used with the players instrument for natural playing position. This is a great advantage over the traditional 'rim-on-a-stick' type visualizers, as Marcinkiewicz visualizers can show the effects of playing angle and pressure. Our visualizers are available in Trumpet, Cornet, Flugelhorn, French Horn, Tenor Trombone, Bass Trombone and Tuba. Visualizers with specific rim sizes are available on special order.

593 S.E 1st Avenue • Canby, Oregon 97013

Ph. 503-263-2456

Fax 503-263-2484

email:mmpco@teleport.com

Pro-Line Concert Hall™ (pat. pending) Tuba Mouthpieces



Designed for the player whose needs are not met elsewhere, these mouthpieces affords enhanced projection, even timbre from ppp to fff, and the same great intonation throughout all registers that Marcinkiewicz mouthpieces are famous for.

Pro-Line Concert Hall™ mouthpieces have a unique exterior design that offers optimal nodal enhancement by placing integral vibration dampers in specific, calculated areas. The net result is a mouthpiece that gives an extremely stable center of pitch, allows unprecedented dynamic levels without distortion and provides a rich, dark symphonic sound without the additional mass of a conventional heavy wall mouthpiece.

Pro-Line Concert Hall™ mouthpieces can be custom fitted to suit your needs.

Pro-Line Concert Hall™ mouthpieces are optimized to give the player the best efficiency possible without compromise.

All Pro-Line Concert Hall™ mouthpieces are special order and custom work is available upon request.

Dark Symphonic Sound

Gray shaded represent comparisons of “classic” models.

Pro-Line Concert Hall™ Model No.	Outside Cup dia.	Inside Cup dia.	Cup Depth	Drill Venturi	Length	Comparison only
H2	1.873 in. 47.57 mm	1.323 in. 33.60 mm	1.582 in. 40.18 mm	0.328 in. 8.33 mm	3.800 in. 96.52 mm	Conn Helleberg
H4	1.873 in. 47.57 mm	1.323 in. 33.60 mm	1.176 in. 37.26 mm	0.328 in. 8.33 mm	3.800 in. 96.52 mm	Conn Helleberg
N1	1.940 in. 49.28 mm	1.325 in. 33.66 mm	1.517 in. 38.53 mm	0.302 in. 7.67 mm	3.800 in. 96.52 mm	Mirafone C3
N4	1.940 in. 49.28 mm	1.325 in. 33.66 mm	1.352 in. 34.34 mm	0.302 in. 7.67 mm	3.800 in. 96.52 mm	Mirafone C3
N4	1.876 in. 47.65 mm	1.290 in. 32.77 mm	1.443 in. 36.65 mm	0.323 in. 8.20 mm	3.800 in. 96.52 mm	Bach 18

593 S.E 1st Avenue • Canby, Oregon 97013

Ph. 503-263-2456

Fax 503-263-2484

email:mmpco@teleport.com

Biographical Information



Playing trumpet professionally since the 10th grade, skill and reputation have enabled Mr. Marcinkiewicz to compile credits with bands and orchestras throughout the world including [Stan Kenton](#), [Arthur Fiedler](#), [Don Ellis](#), [Ray Charles](#), [Portland Festival Symphony](#), [Roger Williams](#), and [The Portland Pops](#), to mention a few, giving him a vast understanding of the performing arts.

Mr. Marcinkiewicz has acquired diverse instruction. His Music studies include work at The University of Washington, San Francisco State University, San Francisco Conservatory of Music and the US Naval School of Music, Norfolk, Virginia. In addition, he has studied with such notables as [Johnny Coppola](#), [Dr. Don Reinberg](#), [Dr. Renold Schilke](#), [Uan Rasey](#), [Roy Stevens](#), [Bob Findley](#) and [Carmine Caruso](#). Teaching privately, Mr. Marcinkiewicz offers a wealth of knowledge regarding teaching methods and is a highly respected authority in the area of embouchure pedagogy - a real "[Dean of Chops](#)". Apart from private instruction, Mr. Marcinkiewicz directed the Marylhurst Jazz Arts Ensemble at Marylhurst College, Lake Oswego, Oregon. In addition, he gives lectures on mouth-

pieces and embouchure development around the world.

In the field of brass technology, Marcinkiewicz Company is recognized as a manufacturer of the [world's highest quality brasswind mouthpieces and hand crafted brass instruments](#). Beginning brass instrument repair in 1965, today Mr. Marcinkiewicz is regarded as a master mouthpiece designer and brass instrument technician. His mouthpiece design studies began in 1973 under the tutelage of legendary master designer and craftsman Burt Herrick. Manufacturing of the Marcinkiewicz Brasswind Mouthpiece began in 1983. The company produces models for some of the top players in the world today.

The Marcinkiewicz Company is housed in their new state of the art facility in Canby, Oregon. The operation is equipped with the [latest computer aided design software and single point cutting technology, with CNC \(Computer Numeric Control\) lathes](#). The results are a wide range of brasswind mouthpieces that are unrivaled in quality, precision, efficiency and choice.

The company also produces a full line of [hand crafted brass instruments](#). [All fabrication, assembly and plating are done on site](#). The finished product, whether a mouthpiece or horn, reflects the perfect blend of "[old world](#)" [craftsmanship and modern technology](#).

Knowledge, choice, quality and precision are the reputation of Joe Marcinkiewicz and the Marcinkiewicz Company.



"Put your money where your mouth is!"™

593 S.E 1st Avenue • Canby, Oregon 97013

Ph. 503-263-2456

Fax 503-263-2484

email:mmpco@teleport.com

PRODUCT WARRANTY DEALER EXCHANGE GUARANTEE

Marcinkiewicz Co. warrants each of its precision brasswind mouthpieces against defects in materials or workmanship for a period of one (1) year from the date of purchase (with proof of purchase) and agrees to repair or exchange any defective mouthpiece without charge within such period.

In addition, Marcinkiewicz Co. offers a Dealer Exchange Program in which dealers may return unsold product, in original packaging, postage prepaid, for a prompt and courteous exchange for other merchandise.



**“Put Your Money
Where Your Mouth Is!TM”
- J. Marcinkiewicz**